



A Reasonable Facsimile Thereof Committing Commerce

Volume 16, Issue 7
July, 2003

Many dealers take advantage of the convenience of using their fax machines to communicate with us. It's quick and easy, and it works 24 hours a day. Everything from parts and accessories orders to research requests to the occasional order status request flows through those copper wires in an unending stream. I have two staff members dedicated to making sure your clean fax orders are input quickly. Our commitment is they are input within the hour.

To better accommodate the volume of faxes coming through, Billiou's recently invested in a new BISCUM 3100L Fax Server. Sure it was expensive, but our customers are worth it.

This new system moves us away from the standalone fax machines we grew up with and now handles faxes in a network environment.

What this means is that faxes are now routed to our desktop computers, creating a level of ease and efficiency impossible to achieve with paper fax machines.

Billiou's staff also has the ability to fax out from their computers as well. Parts breakdowns, technical service information, proof of deliveries, and pretty much anything else you might need from us can now be sent with a few keystrokes on our keyboards.

At the same time we invested in the new server, we also made some changes in our phone lines to accommodate increased fax traffic. We can effectively handle 2,880 faxes during a typical eight hour workday. Folks, that's a fax every second, and we can handle six fax transmissions simultaneously. If that's not enough, we've got plenty of room to grow the system in the future.

Being a rather conservative individual, I won't commit to this until I see proof from the phone company records, but it looks like we can now boast of a **Never-Busy Fax Order Line** for our valued customers.

As of this writing, we've processed over 3,600 faxes through this new system since June 3rd.

Shop labor rates are critically important to your business. Too high, your customers will likely go to your competition. Too low, your customers will love you while you last — and maybe miss you when you're gone.

Several years ago while conducting a business management class I asked those in attendance how they determined their shop labor rates. The overwhelming majority said they set it near the rate others were charging in their area. Terrific idea if the other business has exactly the same fixed and variable expenses as you do, but since this isn't very likely we need a better game plan.

There are seven easy steps to determining a fair and profitable shop labor rate:

- 1.) Determine the yearly operating expenses for the service department
- 2.) Determine the yearly investment costs for the service department
- 3.) Determine service department payroll costs
- 4.) Estimate additional charges incurred by the service department
- 5.) Calculate the total expenses for the service department
- 6.) Identify the total amount of billable hours billed by the service department
- 7.) Calculate your shop labor rate.

Sounds more complicated than it is. Next month, we'll discuss the steps and start doing the math.

Billiou's Marketplace Weather Forecast

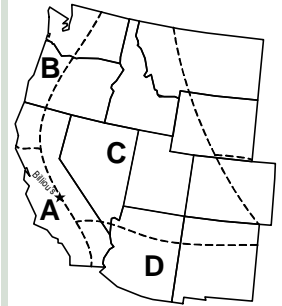

Region A (California):
Avg. Temp: 73° (3° > avg.)
Precipitation: 0" (avg.)
July 1-7 Coastal fog; sunny, hot inland
July 8-12 Sunny, cool
July 13-19 Sunny, warm
July 20-22 Partly sunny; scattered t-storms north
July 23-31 Sunny, warm

Region B (Pacific NW):
Avg. Temp: 71° (3° > avg.)
Precipitation: 0.5" (0.5" < avg.)
July 1-7 Sunny
July 8-10 Sunny, hot
July 11-16 Partly sunny
July 17-22 Sunny, hot
July 23-27 Partly sunny
July 28-31 Partly sunny, showers

Region C (Rocky Mtns):
Avg. Temp: 74° (avg.)
Precipitation: 1" (avg.)
July 1-7 Sunny, hot
July 8-12 Showers, seasonable
July 13-17 Sunny, warm
July 18-24 T-storms
July 25-31 Sunny, hot

Region D (SW Desert):
Avg. Temp: 90.5° (2.5° > avg.)
Precipitation: 0.5" (0.5" < avg.)
July 1-6 Sunny, record heat
July 7-13 Partly sunny; scattered t-storms
July 14-21 Sunny, hot
July 22-31 Hot; scattered t-storms

Quoted Source: *Almanac.com*

RICK GROVES, EDITOR
rickg@billious.com

Homelite Parts Available to Ship

Billiou's has been recently appointed as the **Factory Authorized Homelite Parts Distributor** for non-warranty dealer sales for all states west of the Mississippi River.



Authorized Homelite dealers should still consider existing distribution as their primary parts source, since those distributors are still in place and offer full dealer discount. But if you are a trade account or simply need a part quickly, we are happy to serve your needs with a courtesy trade discount of 19%.



**Save
10%
All Suffix Square Cut
and Round Trimmer Line**

Suffix Manual Heads

July Trimmer Head & Line Special!

Part #	Model #	Description	Dealer	Special!
700-015	SQ-202	5 Adapter, .095" Square	12.49	9.98
700-013	Precision Trim	Universal	10.99	8.88

Suffix Semi-Auto Heads

Part #	Model #	Description	Dealer	Special!
700-001U	SQ-92A	Semi-Auto, Two-Line, 5 Adapter	14.72	12.53
700-022	SQ-65A	Semi-Auto, Lightweight, Single-Line	13.41	12.26

Veri Heads

Part #	Description	Dealer	Special!
VP10ADU	Heavy Duty Twist Feed	11.25	9.88
VP30ADU	Bump and Go	19.59	17.30
VP35ADU	Pro Bump	20.01	17.50
VP80ADU	Mini Bump	14.45	13.01
VP85JX	2-Line Mini Bump	13.78	12.40

Fax orders 800-266-7337 attn: Glenda Penic, or phone her at 800-245-5468 ext. 143
Prices good through July, 31, 2003

Humor Is, As Humor Does



BILLIOUS, INC.

1343 S. Main St.
Porterville, CA 93257

Phone: 559-784-4102
Fax: 559-781-1875
Email: letushelp@billious.com
Web: http://www.billious.com

A Linguistics professor was lecturing his class.

"In English," he explained, "a double negative forms a positive. In some languages, such as Russian, a double negative is still a negative.

"However," the professor continued, "there is no language in which a double positive can form a negative."

A voice from the back of the room piped up, "Yeah, right." ☺

Watching What You Eat

For those of you who watch what you eat, here's the final word on nutrition and health. It's a relief to know the truth after all those conflicting medical studies.

1. Japanese people usually eat very little fat and suffer fewer heart attacks than Britons or Americans.

2. Mexican people usually eat more fat and suffer fewer heart attacks than Britons or Americans.

3. Italian people often drink excessive amounts of red wine and suffer fewer heart attacks than Britons or Americans.

4. Japanese people drink very little red wine and suffer fewer heart attacks than Britons or Americans.

5. German people often drink a lot of beer and eat lots of sausages and fats and suffer fewer heart attacks than Britons or Americans.

CONCLUSION: Eat and drink what you like. Apparently speaking English is what kills you. ☺

While standing watch in the Coast Guard station in Juneau, Alaska, I got a call from the Navy in the nearby city of Adak. They had lost contact with one of their planes, and needed the Coast Guard to send an aircraft to go find it.

I asked the sailor where the Navy aircraft had last been spotted so we would know where to search.

There was a brief moment of silence, followed by, "Sir, I can't tell you that. That information's classified." ☺